

InnoDisk FiD 2.5" SATA4000

InnoDisk FiD 2.5" SATA4000

Datasheet Ver 1.1

Table of contents

1.	Product Overview.....	7
1.1	Introduction of InnoDisk FiD 2.5" SATA4000	7
1.2	Product View	7
1.3	Product Models	7
1.4	SATA Interface.....	7
1.5	2.5-inch form factor	7
1.6	Capacity	8
2.	Theory of operation.....	9
2.1	Overview	9
2.2	SATA I Controller	9
2.3	ATA Controller.....	9
2.4	Error Detection and Correction	9
2.5	Wear-Leveling	10
2.6	Bad Blocks Management	10
3.	Installation Requirements	11
3.1	FiD 2.5 SATA4000 Pin Directions	11
3.2	Electrical Connections for FiD 2.5 SATA4000.....	11
3.3	Form Factor.....	11
3.4	Device drive	12
4.	Specifications	13
4.1	CE and FCC Compatibility	13
4.2	Environmental Specifications	13
4.2.1	Temperature Ranges	13
4.2.2	Humidity	13
4.2.3	Shock and Vibration.....	13
4.2.4	Mean Time between Failures (MTBF)	13
4.3	Endurance	14
4.4	Transfer Mode	14
4.5	Pin Assignment	14
4.6	Mechanical Dimensions	15
4.7	Assembly weight	16
4.8	Performance.....	16
4.9	Seek Time	16
4.10	Hot Plug.....	16
4.11	NAND Flash Memory	16

4.12 Electrical Specifications.....	16
4.12.1 Power Requirement	16
4.12.2 Power Consumption	17
5. Supported ATA Commands.....	18
6. Device Parameters.....	19

REVISION HISTORY

Revision	Description	Date
1.0	First released	January 2008
1.1	Modify storage temperature & add 16/32 GB CHS value	April 2008

List of Tables

TABLE 1: SHOCK/VIBRATION TESTING FOR INNODISK FiD 2.5" SATA4000.....	13
TABLE 2: INNODISK FiD 2.5" SATA4000 MTBF	14
TABLE 3: INNODISK FiD 2.5" SATA4000 PIN ASSIGNMENT	14
TABLE 4: INNODISK FiD 2.5" SATA4000 POWER REQUIREMENT.....	16
TABLE 5: POWER CONSUMPTION	17
TABLE 6: DEVICE PARAMETERS.....	19
TABLE 7: ATA COMMANDS	18

List of Figures

FIGURE 1: INNO_DISK FiD 2.5" SATA4000	7
FIGURE 2: INNO_DISK FiD 2.5" SATA4000 BLOCK DIAGRAM.....	9
FIGURE 3: SIGNAL SEGMENT AND POWER SEGMENT.....	11
FIGURE 4: FiD 2.5" SATA4000 MECHANICAL SCREW HOLE.....	12
FIGURE 5: FiD 2.5 SATA4000 MECHANICAL DIMENSIONS	15

1. Product Overview

1.1 Introduction of InnoDisk FiD 2.5" SATA4000

InnoDisk FiD 2.5" SATA4000 products provide high capacity flash memory Solid State Drive (SSD) that electrically complies with Serial ATA (SATA) standard. InnoDisk FiD 2.5" SATA4000 support SATA I standard (1.5Hz) with high performance. Sustain read is 37MB(Max) per second, and sustain write is 34MB(Max) per second. InnoDisk FiD 2.5" SATA4000 uses standard 2.5-inch form factor, which can be used in laptop. InnoDisk FiD 2.5" SATA4000 is also designed for industrial field. The SSD have good performance, and have small latency time. It effectively reduces the booting time of operation system and the power consumption is less than hard disk drive (HDD). InnoDisk FiD 2.5" SATA4000 can work in harsh environment. The SSD is vibration resistance, and can work in lower or higher temperature than HDD. InnoDisk FiD 2.5" SATA4000 complies with ATA protocol, no additional drives are required, and the SSD can be configured as a boot device or data storage device.

1.2 Product View



Figure 1: InnoDisk FiD 2.5" SATA4000

1.3 Product Models

InnoDisk FiD 2.5" SATA4000 is available in capacities ranging from 128MB to 8GB, making the upgrade path simple and fast.

1.4 SATA Interface

InnoDisk FiD 2.5" SATA4000 support SATA I interface. InnoDisk FiD 2.5" SATA4000 is compliant with Serial ATA Gen 1 specification (Gen1 supports 1.5Gbps data rate).

SATA connector uses a 7-pin signal segment and a 15-pin power segment.

1.5 2.5-inch form factor

Industry 2.5-inch standard form factor design with metal material case is easy for installation because 2.5-inch is a popular form factor in industrial field. 2.5-inch is most laptop's hard disk's form factor.

InnoDisk FiD 2.5" SATA4000 SSD can easy install in laptop. InnoDisk FiD 2.5" SATA4000 has a compact design 100mm (L) x 69.5mm (W) x 9.5mm (H).

1.6 Capacity

InnoDisk provides unformatted 128MB, 256MB, 512MB, 1GB, 2GB, 4GB and 8GB capacities for InnoDisk FiD 2.5" SATA4000 product.

2. Theory of operation

2.1 Overview

Figure 2 shows the operation of InnoDisk FiD 2.5" SATA4000 from the system level, including the major hardware blocks.

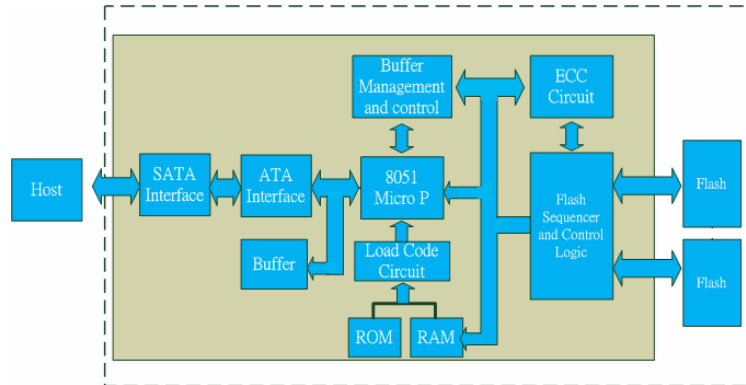

Figure 2: InnoDisk FiD 2.5" SATA4000 Block Diagram

InnoDisk FiD 2.5" SATA4000 integrates a SATA I bridge controller, an ATA controller and NAND flash memories. Communication with the host occurs through the host interface, using the standard ATA protocol. Communication with the flash device(s) occurs through the flash interface.

2.2 SATA I Controller

The SATA I bridge controller is 1.5 Gbps (Gen. 1), and support hot-plug. The main function is to bridge between a legacy IDE storage device and a Serial ATA host. The Serial ATA physical, link and transport layers are compliant with Serial ATA Gen 1 specification (Gen 1 supports 1.5Gbps data rate). The data burst rate between SATA I bridge controller and ATA controller is 100MB/sec.

2.3 ATA Controller

The ATA controller is equipped with 12KB of internal memory that is used for storing data. The internal memory can also be used as an intermediate memory for storing data blocks during a wear-leveling procedure. There are 40KB of internal memory is used for code. A 10KB internal boot ROM includes basic routines for accessing the flash memories and for loading the main code into the internal memory.

2.4 Error Detection and Correction

Highly sophisticated Error Correction Code algorithms are implemented. The ECC unit consists of the Parity Unit (parity-byte generation) and the Syndrome Unit (syndrome-byte computation). This unit implements an algorithm that can correct four bits per 512 bytes in an ECC block. Code-byte generation during write operations, as well as error detection during read operation, is implemented on the fly without any speed penalties.

2.5 Wear-Leveling

Flash memory can be erased within a limited number of times. This number is called the ***erase cycle limit*** or ***write endurance limit*** and is defined by the flash array vendor. The erase cycle limit applies to each individual erase block in the flash device.

InnoDisk FiD 2.5" SATA4000 uses a wear-leveling algorithm to ensure that consecutive writes of a specific sector are not written physically to the same page/block in the flash. This spreads flash media usage evenly across all pages, thereby extending flash lifetime.

2.6 Bad Blocks Management

Bad Blocks are blocks that contain one or more invalid bits whose reliability are not guaranteed. The Bad Blocks may be presented while the SSD is shipped, or may develop during the life time of the SSD. The Bad Blocks will not exceed more than 3% of the total device volume. When the Bad Blocks is detected, it will be flagged, and not be used anymore. The SSD implement Bad Blocks management, Bad Blocks replacement, Error Correct Code to avoid data error occurred. The functions will be enabled automatically to transfer data from Bad Blocks to spare blocks, and correct error bit.

3. Installation Requirements

3.1 FiD 2.5 SATA4000 Pin Directions

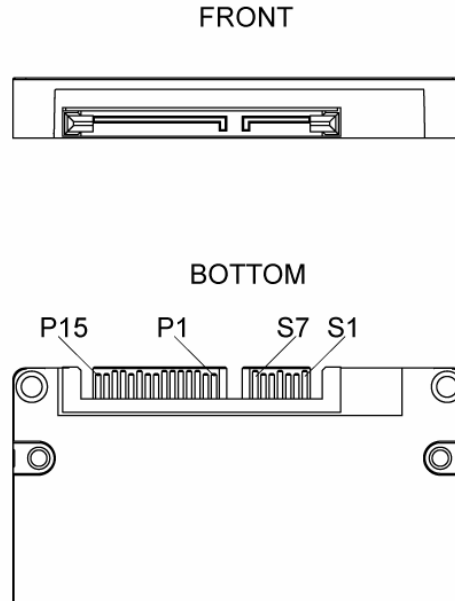

Figure 3: Signal Segment and Power Segment

3.2 Electrical Connections for FiD 2.5 SATA4000

A Serial ATA device may be either directly connected to a host or connected to a host through a cable. For connection via cable, the cable should be no longer than 1 meter.

The SATA interface has a separate connector for the power supply. Please refer to the pin description for further details.

3.3 Form Factor

Please prepare following things:

- Screw driver.
- Four M3 screws.
- SATA single cable (7-pin, Maximum length 1 meter).
- SATA power cable (15-pin).

Please turn off your computer, and open your computer's case. Find one of available 2.5-inch slot, and plug the SSD in. To use the screws fix the SSD. Plug in the SATA single cable, and power cable.

Please boot the installation Operation System from CD-ROM, and install Operation System into SSD.

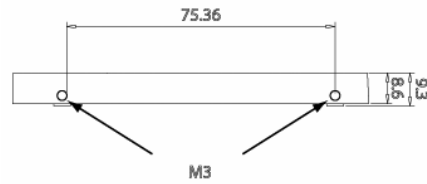

Figure 4: FiD 2.5" SATA4000 Mechanical Screw Hole

3.4 Device drive

No additional device drives are required. The InnoDisk FiD 2.5" SATA4000 can be configured as a boot device.

4. Specifications

4.1 CE and FCC Compatibility

- **CE Compatibility**

InnoDisk FiD 2.5" SATA4000 conforms to CE requirements.

- **RoHS Compliance**

InnoDisk FiD 2.5" SATA4000 is fully compliant with RoHS directive.

4.2 Environmental Specifications

4.2.1 Temperature Ranges

Operating Temperature Range:

- Standard Grade: -10°C to +70°C
- Industrial Grade: -40°C to +85°C

Storage Temperature Range:

- Standard Grade: -55°C to +95°C
- Industrial Grade: -55°C to +95°C

4.2.2 Humidity

Relative Humidity: 10-95%, non-condensing

4.2.3 Shock and Vibration

Table 1: Shock/Vibration Testing for InnoDisk FiD 2.5" SATA4000

Reliability	Test Conditions	Reference Standards
Vibration	7 Hz to 700 Hz, 2 g, 3 axes	IEC 68-2-6
Mechanical Shock	Duration: 0.5ms, 1500 g, 3 axes	IEC 68-2-27
Drop Unit	From a height of 1.5 m	IEC 68-2-32

4.2.4 Mean Time between Failures (MTBF)

Table 4 summarizes the MTBF prediction results for various InnoDisk FiD 2.5" SATA4000 configurations. The analysis was performed using a RAM Commander™ failure rate prediction.

- **Failure Rate:** The total number of failures within an item population, divided by the total number of

life units expended by that population, during a particular measurement interval under stated condition.

- **Mean Time between Failures (MTBF):** A basic measure of reliability for repairable items: The mean number of life units during which all parts of the item perform within their specified limits, during a particular measurement interval under stated conditions.

Table 2: InnoDisk FiD 2.5" SATA4000 MTBF

Product	Condition	MTBF (Hours)
InnoDisk FiD 2.5" SATA 4000	Telcordia SR-332 GB, 25 °C	> 3,000,000

4.3 Endurance

Read Cycles: Unlimited Read Cycles.

Write /Erase Cycles: 2,000,000 Erase Cycles.

Data Retention: 10 years.

Wear-Leveling Algorithm: support.

Bad Blocks Management: Support

Error Correct Code: Support

4.4 Transfer Mode

InnoDisk FiD 2.5" SATA4000 support following transfer mode:

PIO Mode: 0~4.

Multiword DMA: 0~2.

Ultra DMA: 0~5.

Serial ATA I: 1.5Gbps

4.5 Pin Assignment

InnoDisk FiD 2.5" SATA4000 uses a standard SATA pin-out. See Table 3 for InnoDisk FiD 2.5" SATA4000 pin assignments.

Table 3: InnoDisk FiD 2.5" SATA4000 Pin Assignment

Name	Type	Description	Note
S1	GND		
S2	A+	Differential Signal Pair A	
S3	A-		
S4	GND		
S5	B-	Differential Signal Pair B	

S6	B+		
S7	GND		
Key and Spacing separate signal and power segments			
P1	V33	3.3V Power	
P2	V33	3.3V Power	
P3	V33	3.3V Power, Pre-charge	
P4	GND		
P5	GND		
P6	GND		
P7	V5	5V Power, Pre-Charge	
P8	V5	5V Power	
P9	V5	5V Power	
P10	GND		
P11	DAS/DSS	Device Activity Signal / Disable Staggered	
P12	GND		
P13	V12	12V Power, Pre-charge	
P14	V12	12V Power	
P15	V12	12V Power	

4.6 Mechanical Dimensions

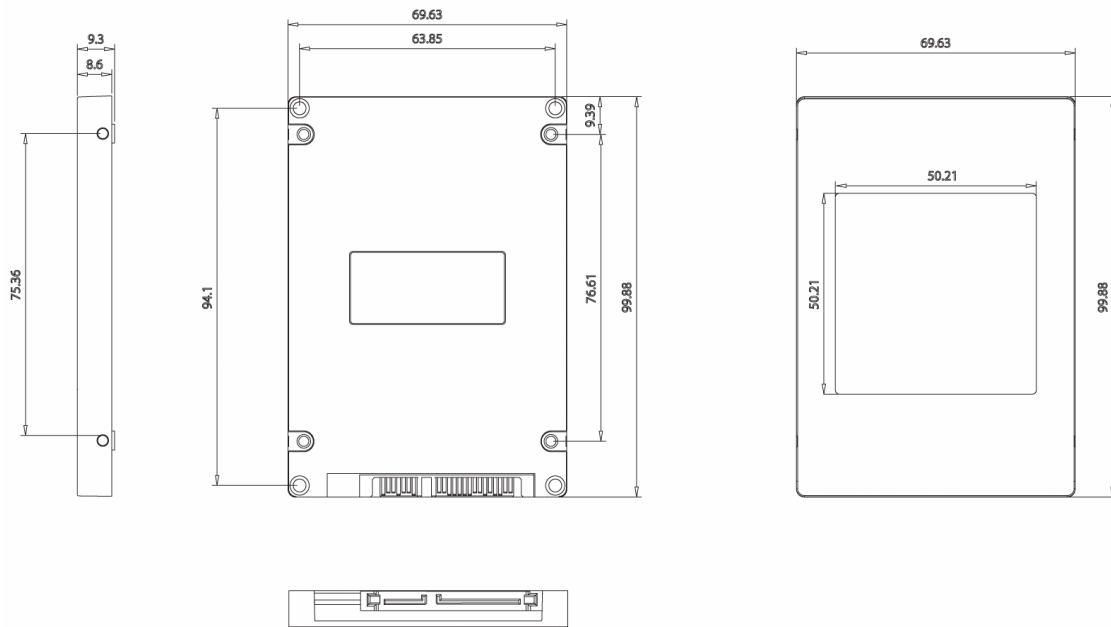

Figure 5: FiD 2.5 SATA4000 mechanical dimensions

4.7 Assembly weight

An InnoDisk FiD 2.5" SATA4000 8GB's weight is 95 grams approx. If the capacity is different, the flash chip's weight needs to be added. However, the total weight of SSD will be less than 100 grams.

4.8 Performance

Burst Transfer Rate: 1.5Gbps
 Sustained Read : Dual Channel: 37MB/sec (MAX) ; Single Channel:20MB/sec (MAX)
 Sustained Write : Dual Channel: 34MB/sec (MAX) ; Single Channel: 20MB/sec (MAX)
 Average Latency : 0.4 ms

4.9 Seek Time

InnoDisk FiD 2.5" SATA4000 is not a magnetic rotating design. There is no seek or rotational latency required.

4.10 Hot Plug

The SSD support hot plug function and can be removed or plugged-in during operation. User has to avoid hot plugging the SSD which is configured as boot device and installed operation system.

Surprise hot plug : The insertion of a SATA device into a backplane (combine signal and power) that has power present. The device powers up and initiates an OOB sequence.

Surprise hot removal: The removal of a SATA device from a powered backplane, without first being placed in a quiescent state.

4.11 NAND Flash Memory

InnoDisk FiD 2.5" SATA4000 uses Single Level Cell (SLC) NAND flash memory, which is non-volatility, high reliability and high speed memory storage. There are only two statuses 0 or 1 of one cell. Read or Write data to flash memory for SSD is control by micro processor.

4.12 Electrical Specifications

4.12.1 Power Requirement

Table 4: InnoDisk FiD 2.5" SATA4000 Power Requirement

Item	Symbol	Rating	Unit
DC Power Supply	V _{DD}	-0.3 ~ +5.5	V
Input voltage	V _{IN}	-0.3 ~ +5.5	V
Output voltage	V _{OUT}	-0.3 ~ +3.8	V

Operating Temperature	T _A	Standard: -10 ~ +70 Industrial: -40 ~ +85	°C
Storage Temperature	T _{ST}	Standard: -55 ~ +95 Industrial: -55 ~ +95	°C

4.12.2 Power Consumption

Table 5: Power Consumption

Mode	Power Consumption
Read	1W
Write	1.2W
Idle	0.7W

5. Supported ATA Commands

InnoDisk FiD 2.5" SATA4000 supports the commands listed in Table 7.

Table 7: ATA Commands

Command Name	Command Code	Support
Check Power Mode	E5H (98H)	Yes
Execute Device Diagnostic	90H	Yes
Format Track	(50H)	Yes
Identify Device	ECH	Yes
Idle	E3H (97H)	Yes
Idle immediate	E1H (95H)	Yes
Initialize Device Parameters	(91H)	Yes
NOP	00H	Yes
Read Buffer	E4H	Yes
Read Long Sector	(22H or 23H)	Yes
Read Multiple	C4H	Yes
Read Sector(s)	20H or 21H	Yes
Read Verify Sector	40H or 41H	Yes
Read DMA	C8H	Yes
Recalibrate	(1XH)	Yes
Seek	70H	Yes
Set Features	EFH	Yes
Set Multiple Mode	C6H	Yes
Set Sleep Mode	E6H (99H)	Yes
Standby	E2H (96H)	Yes
Standby Immediate	E0H (94H)	Yes
Write Buffer	E8H	Yes
Write Multiple	C5H	Yes
Write Sector	30H	Yes
Write DMA	CAH	Yes
Write Verify	(3CH)	Yes
Security Set Password	F1H	Yes
Security Unlock	F2H	Yes
Security Erase Prepare	F3H	Yes
Security Erase Unit	F4H	Yes
Security Freeze Lock	F5H	Yes
Security Disable Password	F6H	Yes

6. Device Parameters

FiD 2.5 SATA4000 device parameters listed in Table 6.

Table 6: Device parameters

Capacity	LBA	Cylinders	Heads	Sectors
128MB	250992	249	16	63
256MB	502992	499	16	63
512MB	1006992	999	16	63
1GB	2014992	1999	16	63
2GB	3996720	3965	16	63
4GB	7994448	7931	16	63
8GB	15989904	15863	16	63
16GB	31981568	16383	16	63
32GB	63963136	16383	16	63