

## Venus634LPx-T 65 Channel Timing Mode GPS Receiver

### FEATURES

- Complete GPS receiver module in 10 x 10 x 1.1 mm
- 51 channel acquisition, 14 channel tracking
- 8 million time-frequency hypothesis testing per sec
- Open Sky hot start 1 second, cold start 29 second
- Signal detection sensitivity -161dBm
- 30nsec (1-sigma) timing accuracy
- Position hold mode for GPS timing operation
- 1PPS generation with 1 satellite in view
- ~28mA operating current
- 0.8mm pitch LGA44 package, RoHS compliant

The Venus634LPx-T is a high performance module in a chip design targeting precision timing GPS receiver application. It offers very low current consumption, high sensitivity, and best in class signal acquisition and time to first fix performance.

The Venus634LPx-T contains all the necessary components of a complete GPS receiver module, includes GPS RF front-end, GPS baseband signal processor, 0.5ppm TCXO, 32.768kHz RTC crystal, RTC LDO regulator, and passive components. It requires very low external component count and takes up only 100mm<sup>2</sup> PCB footprint.

Dedicated massive-correlator signal parameter search engine within the baseband enables rapid search of all the available satellites and acquisition of very weak signal. An advanced track engine allows weak signal tracking and continuous reliable precision timing generation in harsh environments such as urban canyons and under deep foliage.

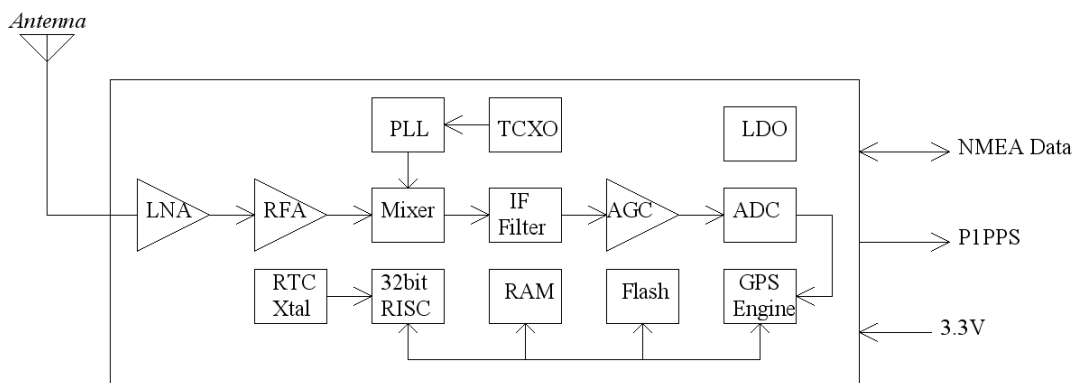
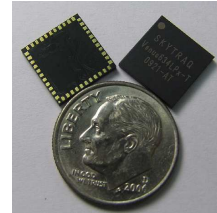

Figure-1 GPS Receiver based on Venus634LPx-T

## TECHNICAL SPECIFICATIONS

Receiver Type	L1 Frequency GPS C/A code SBAS Capable 51 Channel Acquisitions 14 Channel Tracking
Accuracy	Position 2.5m CEP Velocity 0.1m/sec Time 30nsec (1-sigma) < 60nsec (99%)
Open Sky TTFF	Hot start 1 second Cold start 29 seconds average
Reacquisition	< 1s
Sensitivity	Tracking -161dBm
Update Rate	1Hz standard
Dynamics	4G
Operational Limits	Altitude < 18,000m <sup>*1</sup> or Velocity < 515m/s <sup>*1</sup>
Datum	Default WGS-84
Interface	UART LVTTTL level
Baud Rate	4800 / 9600 / 38400 / 115200 software configurable (9600 as default)
Protocol	NMEA-0183 V3.01, GGA, GLL, GSA, GSV, RMC, VTG (default GGA, GSA, GSV, RMC, VTG) SkyTraq Binary
Main Supply Voltage	2.8V ~ 3.6V
Backup Voltage	1.5V ~ 6V
Current Consumption	~28mA tracking
Operating Temperature	-40 ~ +85 deg-C
Storage Temperature	-40 ~ +125 deg-C
Package	LGA44 10mm x 10mm x 1.1mm, 0.8mm pitch

\*1: COCOM limit, either may be exceeded but not both

## OPERATION

When Venus634LPx-T is turned on, it automatically begin to acquire and track GPS signals. After valid ephemeris data is collected for each tracked satellite signal and ready for position fix, it performs self-survey of its location in Survey Mode. After 2000 position fixes (configurable) the Venus634LPx-T automatically enters Static Mode, a clock over-determined time-only mode.

Satellites above elevation mask and signal level above CNR mask are used for position fix. Default elevation mask is 5 degrees and CNR mask is 0.

Venus634LPx-T operates Survey Mode, Static Mode, or PVT Mode.

Upon power on, the Venus634LPx-T performs 2000 point position fix self-survey. The number of points used for self-survey may be changed using binary command 0x43. After self-survey is completed, the receiver enters Static Mode.

Static Mode is used in static timing application. It is entered after the receiver self-surveyed its static reference position, or by user input. The over-determined clock solution is checked against TRAIM algorithm to remove faulty satellites from the solution. In this mode the receiver will no longer update its position or velocity, only solving for receiver clock bias and bias rate to maintain the 1PPS output.

The PVT mode is for navigation type of application, less used with timing application. In this mode, TRAIM and single-satellite 1PPS generation is not supported.

# PIN-OUT DIAGRAM

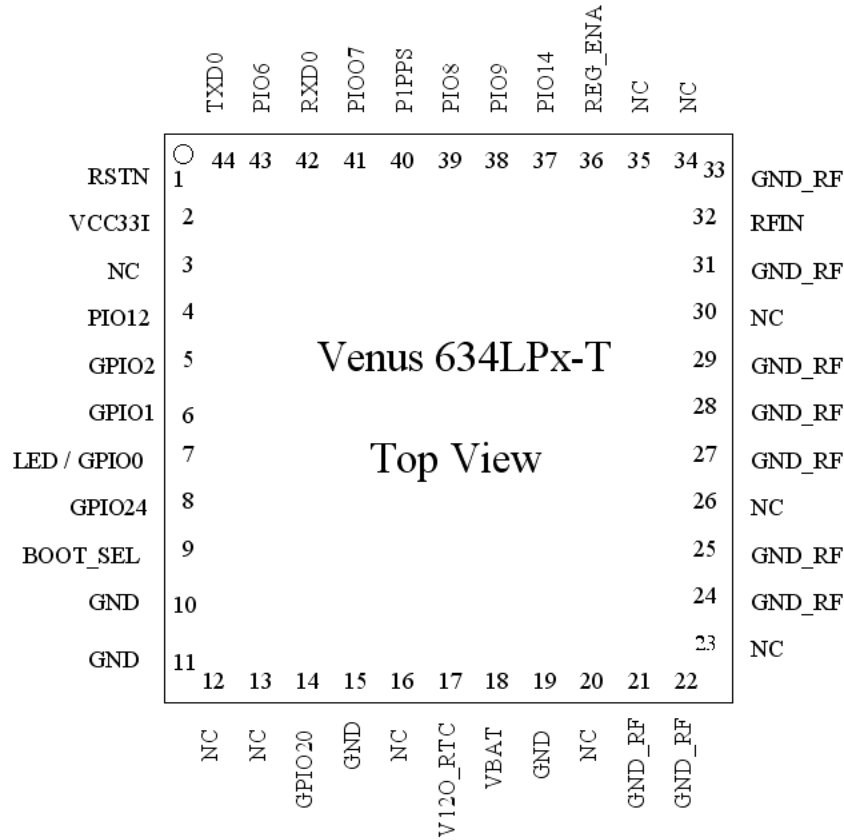

Figure-2 Venus634LPx-T Pin-Out Diagram

# PIN DEFINITION

Pin Number	Signal Name	Type	Description
1	RSTN	Input	Active LOW reset input, 3.3V LVTTTL
2	VCC33I	Power Input	Main voltage supply input, 2.8V ~ 3.6V
3	NC		Not connected, empty pin
4	NC	I/O	No function GPIO pin, leave open
5	NC	I/O	General purpose I/O pin, 3.3V LVTTTL
6	NC	I/O	General purpose I/O pin, 3.3V LVTTTL
7	LED / GPIO0	I/O	Navigation status indicator or General purpose I/O. 3.3V LVTTTL No fix active low. Position fix toggle each second.
8	GPIO24	I/O	General purpose I/O pin. 3.3V LVTTTL Also serves as Search Engine Mode Selection upon power-up 1: low power acquisition mode 0: enhanced acquisition mode
9	BOOT_SEL	I/O	Boot mode selection. Pull-high or pull-low using 10K resistor. Must not connect to VCC or GND directly. 1: execute from internal ROM 0: execute from internal Flash memory
10	GND	Power	System ground
11	GND	Power	System ground
12	NC		Not connected, empty pin
13	NC		Not connected, empty pin
14	GPIO20	I/O	General purpose I/O pin, 3.3V LVTTTL
15	GND	Power	System ground
16	NC		Not connected, empty pin
17	V120_RTC	Power Output	1.2V LDO output for RTC & backup memory. Normally unused.
18	VBAT	Power Input	RTC & backup memory voltage input, 1.5V ~ 6.0V
19	GND	Power	System ground
20	NC		Not connected, empty pin

21	GND_RF	Power	RF section system ground
22	GND_RF	Power	RF section system ground
23	NC		Not connected, empty pin
24	GND_RF	Power	RF section system ground
25	GND_RF	Power	RF section system ground
26	NC		Not connected, empty pin
27	GND_RF	Power	RF section system ground
28	GND_RF	Power	RF section system ground
29	GND_RF	Power	RF section system ground
30	NC		Not connected, empty pin
31	GND_RF	Power	RF section system ground
32	RFIN	Input	GPS signal input, connect to GPS antenna.
33	GND_RF	Power	RF section system ground
34	NC		Not connected, empty pin
35	NC		Not connected, empty pin
36	REG_ENA	Input	Connect to pin-2 VCC33I
37	PIO14	I/O	General purpose I/O pin, 3.3V LVTTTL
38	MOSI / PIO9	I/O	SPI data output or general purpose I/O pin, 3.3V LVTTTL
39	MISO / PIO8	I/O	SPI data input or general purpose I/O pin, 3.3V LVTTTL
40	P1PPS	Output	1 pulse per second output. Active after position fix; goes HIGH for about 1msec, 3.3V LVTTTL
41	SPI_CLK / PIO07	Output	SPI clock or general purpose output pin, 3.3V LVTTTL
42	RXD0	Input	Received input of the asynchronous UART port. Used to input binary command to the GPS receiver. 3.3V LVTTTL
43	SPI_CSN / PIO6	I/O	SPI chip select output or general purpose I/O pin, 3.3V LVTTTL
44	TXD0	Output	Transmit output of the asynchronous UART port. Used to output standard NMEA-0183 sentence or response to input binary command. 3.3V LVTTTL

## DC CHARACTERISTICS OF DIGITAL INTERFACE

Below is when VCC33I is at nominally 3.3V

Parameter	Min.	Typ.	Max.	Units
Input Low Voltage			0.8	Volt
Input High Voltage	2.0			Volt
Output Low Voltage, I <sub>ol</sub> = 2 ~ 16mA			0.4	Volt
Output High Voltage, I <sub>oh</sub> = 2 ~ 16mA	2.9			Volt

# MECHANICAL DIMENSION

Unit = mil

Package size = 393.7 mil x 393.7 mil x 43.3 mil = 10 mm x 10mm x1.1 mm

Package Pad = 15 x 21 mil

Package Pitch= 0.8 mm= 31.5 mil

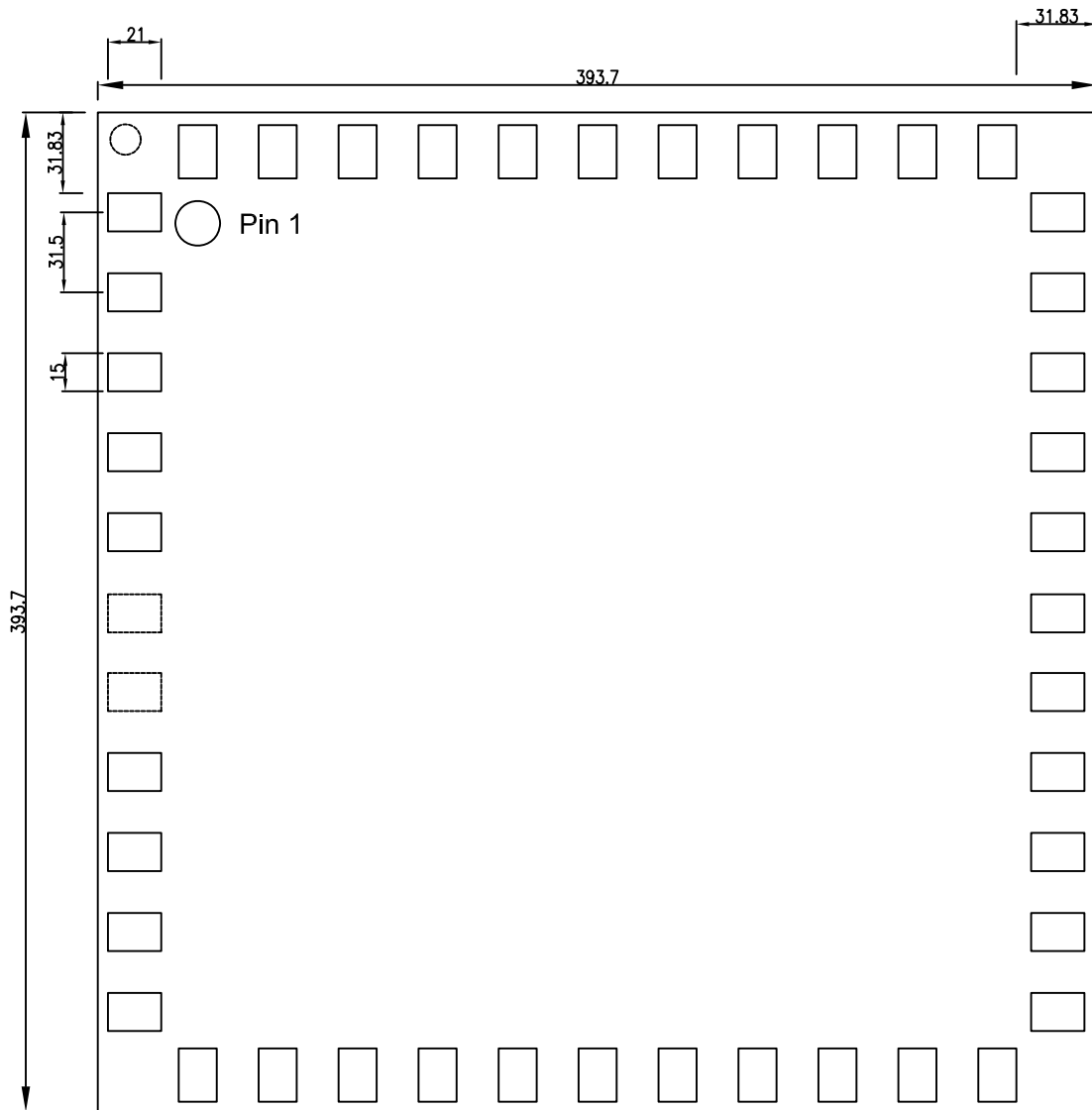

LGA44 Package Top View (transparent, see through to pads)

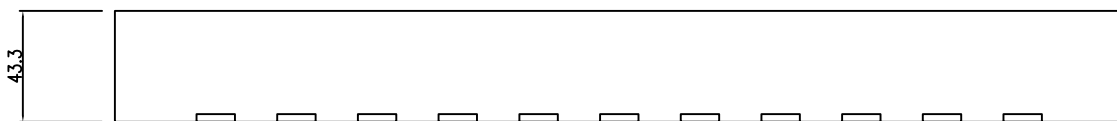

Side View

## RECOMMENDED PCB FOOTPRINT

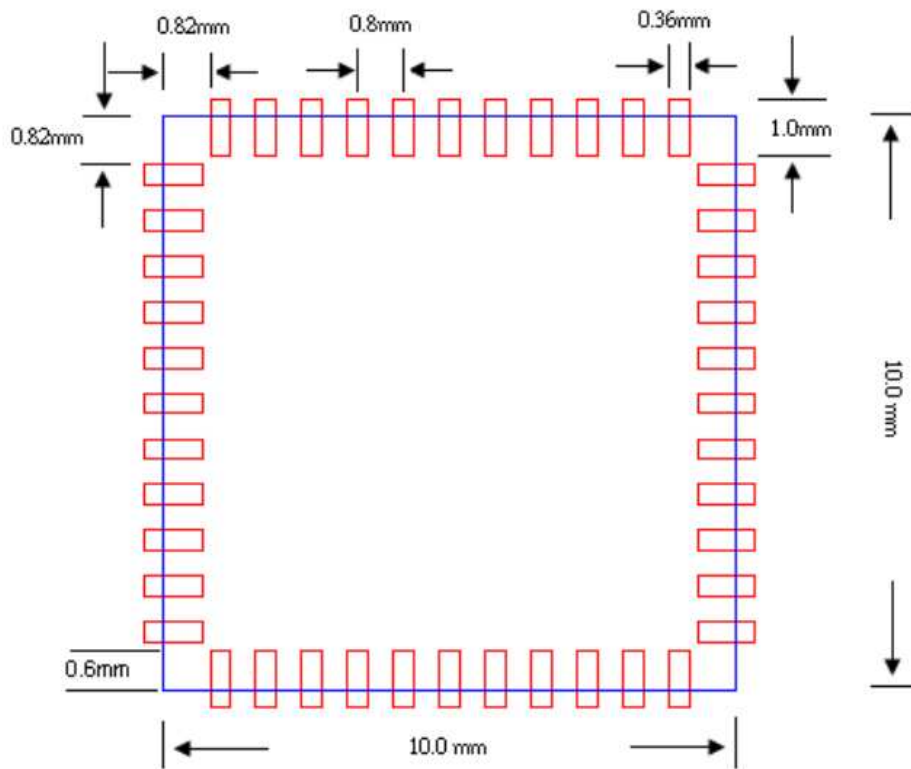
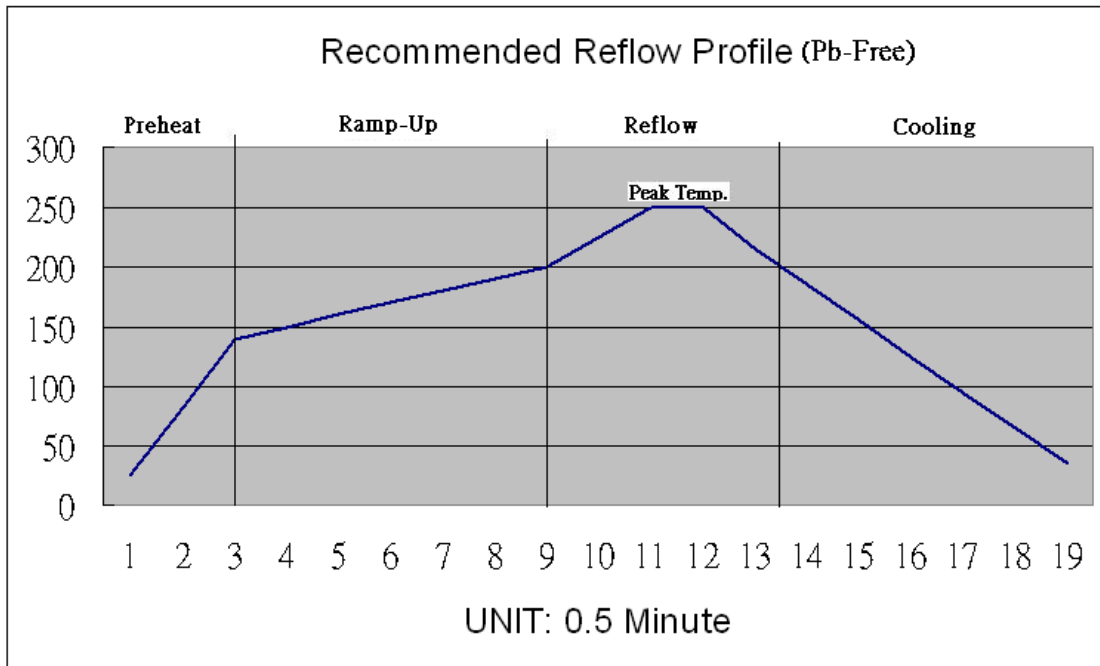

Figure-3 Recommended PCB Footprint.

Blue part is outline of the IC package. Red part is outline of the recommended PCB pad layout.

# RECOMMENDED REFLOW PROFILE



Temperature (°C)	25	82.5	140	150	160	170	180	190	200	225	250	250	215	185	155	125	95	65	35
Time(minute)	0	0.5	1	1.5	2	2.5	3	3.5	4	4.5	5	5.5	6	6.5	7	7.5	8	8.5	9

Profile Description	SnPb Eutectic Process	Lead Free Process
<b>Preheat</b>		
Maximum Temperature	100+/-10 °C	140+/-10 °C
Time(Δ T)	40~60s	50~70s
<b>Ramp-Up</b>		
Ramp-Up Rate	1 °C/s Max.	1 °C/s Max.
Time(Δ T)	120~150s	160~200s
<b>Reflow</b>		
Maximum Temperature	Peak Temp.	Peak Temp.
Minimum Temperature	180+/-5°C	200+/-10°C
Peak Temperature	220+/-2°C	250+/-2°C
Time(Δ T) during Peak Temp.+/-2°C	10~30s	20~40s
Reflow Time(Δ T)	120~150s	120~150s
<b>Cooling</b>		
Cooling Rate	1.5 °C/s Max	1.5 °C/s Max
Time(Δ T)	60~120s	150~180s

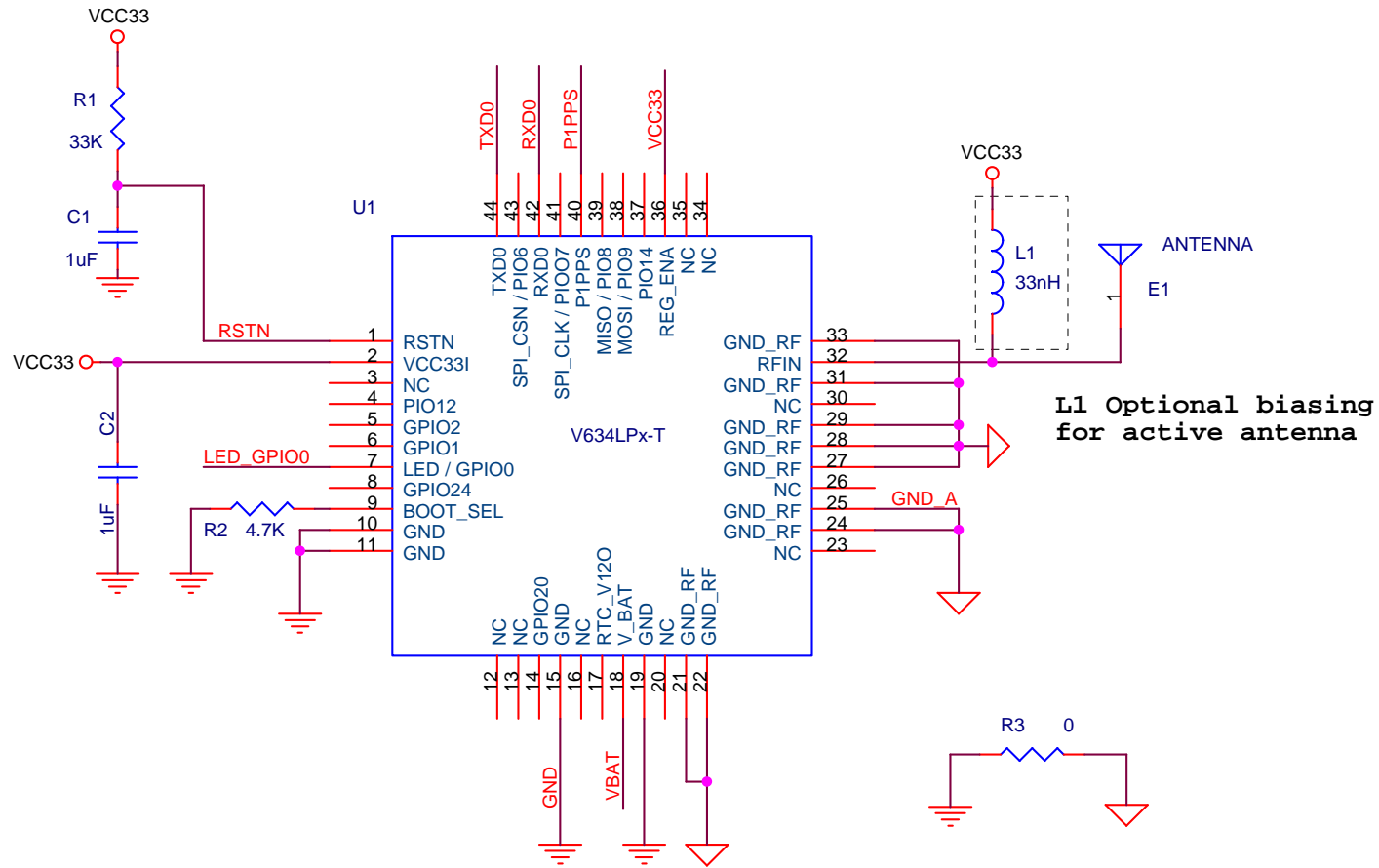

**L1 Optional biasing  
for active antenna**

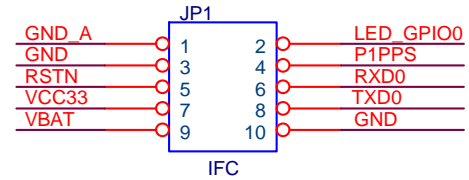
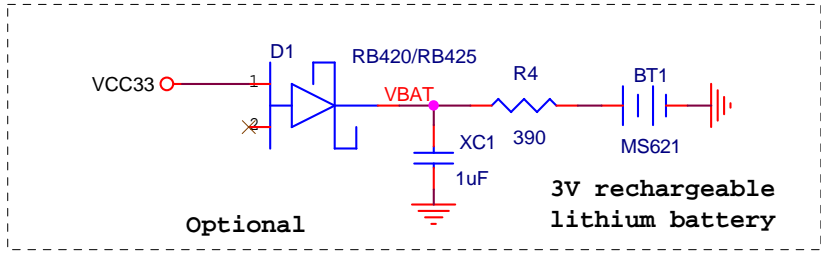

<b>SkyTraQ Technology, Inc.</b>		
Title Venus 634LPx-T Application Circuit		
Size A	Document Number V634LPx-T_AP001	Rev 1.0
Date:	Wednesday, July 29, 2009	Sheet 1 of 1

## APPLICATION CIRCUIT INTERFACE SIGNALS

GND_A:	RF ground
LED_GPIO0:	Signal to indicate GPS position status, or for GPIO (3.3V LVTTTL). Active LOW.
GPIO24:	GPIO pin, also serving as Search Engine Mode Selection upon power-up 1: Low power acquisition mode 0: Enhanced acquisition mode
PIO12, GPIO20:	GPIO pin
GND:	Digital ground
P1PPS:	1 pulse per second time-mark (3.3V LVTTTL)
RSTN:	Active low reset input
PIO14, GPIO1, GPIO2:	GPIO pin
VCC33:	3.3V power input
FRXD0:	UART input (3.3V LVTTTL)
FTXD0:	UART output (3.3V LVTTTL)
VBAT:	Battery-backed RTC and SRAM supply input, must not be unconnected.
SPICSN_PIO6:	SPI chip select output or GPIO pin
MISO_PIO8:	SPI data input or GPIO pin
SPICLK_PIO07:	SPI clock or general purpose output pin
MOSI_PIO9:	SPI data output or GPIO pin

## APPLICATION INFORMATION

1. For fast-rising power supply, a simple series R/C reset to pin-1, RSTN, as indicated in the application circuit is suitable. For system having slow-rising power supply, a reset IC providing 2~5ms reset duration may be necessary.
2. The RF input of Venus634LPx-T is already matched to 50-ohm. Passive antenna matched to 50-ohm can be directly applied.
3. For using Venus634LPx-T with active antenna, one with gain in range of 10~30dB and noise figure < 2dB can be used. Power to the active antenna needs to be applied externally.
4. Pin-18 VBAT supplies backup power to the real-time clock and backup SRAM for fast startup. For portable applications where there is battery with voltage in range of 1.5V ~ 6.0V as the main source, the VBAT pin can be directly connected to it.
5. To put Venus634LPx-T in power-down mode, an external 3V LDO regulator with enable control can be used to provide 3V to pin-2 and pin-36. Disabling the regulator reduces the total current to < 10uA, consumed by the RTC circuitry and backup SRAM through VBAT pin.

When using the described power-down mode, add a series 10K resistor on pin-42.

6. Like BGA device, the Venus634LPx-T is moisture sensitive. It needs to be handled with care to void damage from moisture absorption and SMT re-flow. The device should be baked for 24 hours at 125-degC before mounting for SMT re-flow if it has been removed from the protective seal for more than 48hours.

# NMEA MESSAGES

The full descriptions of supported NMEA messages are provided at the following paragraphs.

## GGA - Global Positioning System Fix Data

Time, position and fix related data for a GPS receiver.

Structure:

```
$GPGGA,hhmmss.sss,ddmm.mmmm,a,dddmm.mmmm,a,x,xx,x.x,x.x,M,,,,,xxxx*hh<CR><LF>
```

1        2        3        4        5 6 7 8 9        10 11

Example:

```
$GPGGA,111636.932,2447.0949,N,12100.5223,E,1,11,0.8,118.2,M,,,,,0000*02<CR><LF>
```

Field	Name	Example	Description
1	UTC Time	111636.932	UTC of position in hhmmss.sss format, (000000.000 ~ 235959.999)
2	Latitude	2447.0949	Latitude in ddmm.mmmm format Leading zeros transmitted
3	N/S Indicator	N	Latitude hemisphere indicator, 'N' = North, 'S' = South
4	Longitude	12100.5223	Longitude in dddmm.mmmm format Leading zeros transmitted
5	E/W Indicator	E	Longitude hemisphere indicator, 'E' = East, 'W' = West
6	GPS quality indicator	1	GPS quality indicator 0: position fix unavailable 1: valid position fix, SPS mode 2: valid position fix, differential GPS mode 3: GPS PPS Mode, fix valid 4: Real Time Kinematic. System used in RTK mode with fixed integers 5: Float RTK. Satellite system used in RTK mode. Floating integers 6: Estimated (dead reckoning) Mode 7: Manual Input Mode 8: Simulator Mode
7	Satellites Used	11	Number of satellites in use, (00 ~ 12)
8	HDOP	0.8	Horizontal dilution of precision, (00.0 ~ 99.9)
9	Altitude	108.2	mean sea level (geoid), (-9999.9 ~ 17999.9)
10	DGPS Station ID	0000	Differential reference station ID, 0000 ~ 1023 NULL when DGPS not used
11	Checksum	02	

### GLL – Latitude/Longitude

Latitude and longitude of current position, time, and status.

Structure:

\$GPGLL,ddmm.mmmm,a,dddmm.mmmm,a,hhmmss.sss,A,a\*hh<CR><LF>

1 2 3 4 5 6 7 8

Example:

\$GPGLL,2447.0944,N,12100.5213,E,112609.932,A,A\*57<CR><LF>

Field	Name	Example	Description
1	Latitude	2447.0944	Latitude in ddmm.mmmm format Leading zeros transmitted
2	N/S Indicator	N	Latitude hemisphere indicator 'N' = North 'S' = South
3	Longitude	12100.5213	Longitude in dddmm.mmmm format Leading zeros transmitted
4	E/W Indicator	E	Longitude hemisphere indicator 'E' = East 'W' = West
5	UTC Time	112609.932	UTC time in hhmmss.sss format (000000.000 ~ 235959.999)
6	Status	A	Status, 'A' = Data valid, 'V' = Data not valid
7	Mode Indicator	A	Mode indicator 'N' = Data not valid 'A' = Autonomous mode 'D' = Differential mode 'E' = Estimated (dead reckoning) mode 'M' = Manual input mode 'S' = Simulator mode
8	Checksum	57	

**GSA – GNSS DOP and Active Satellites**

GPS receiver operating mode, satellites used in the navigation solution reported by the GGA or GNS sentence and DOP values.

Structure:

```
$GPGSA,A,x,xx,xx,xx,xx,xx,xx,xx,xx,xx,xx,xx,x.x,x.x,x.x*hh<CR><LF>
  1 2 3 3 3 3 3 3 3 3 3 3 3 4 5 6 7
```

Example:

```
$GPGSA,A,3,05,12,21,22,30,09,18,06,14,01,31,,1.2,0.8,0.9*36<CR><LF>
```

Field	Name	Example	Description
1	Mode	A	Mode 'M' = Manual, forced to operate in 2D or 3D mode 'A' = Automatic, allowed to automatically switch 2D/3D
2	Mode	3	Fix type 1 = Fix not available 2 = 2D 3 = 3D
3	Satellite used 1~12	05,12,21,22,30,09,18,06,14,01,31,,	Satellite ID number, 01 to 32, of satellite used in solution, up to 12 transmitted
4	PDOP	1.2	Position dilution of precision (00.0 to 99.9)
5	HDOP	0.8	Horizontal dilution of precision (00.0 to 99.9)
6	VDOP	0.9	Vertical dilution of precision (00.0 to 99.9)
7	Checksum	36	

**GSV – GNSS Satellites in View**

Number of satellites (SV) in view, satellite ID numbers, elevation, azimuth, and SNR value. Four satellites maximum per transmission.

Structure:

```
$GPGSV,x,x,xx,xx,xx,xxx,xx,...,xx,xx,xxx,xx *hh<CR><LF>
  1 2 3 4 5 6 7 4 5 6 7 8
```

Example:

```
$GPGSV,3,1,12,05,54,069,45,12,44,061,44,21,07,184,46,22,78,289,47*72<CR><LF>
$GPGSV,3,2,12,30,65,118,45,09,12,047,37,18,62,157,47,06,08,144,45*7C<CR><LF>
$GPGSV,3,3,12,14,39,330,42,01,06,299,38,31,30,256,44,32,36,320,47*7B<CR><LF>
```

Field	Name	Example	Description
1	Number of message	3	Total number of GSV messages to be transmitted (1-3)
2	Sequence number	1	Sequence number of current GSV message
3	Satellites in view	12	Total number of satellites in view (00 ~ 12)
4	Satellite ID	05	Satellite ID number, GPS: 01 ~ 32, SBAS: 33 ~ 64 (33 = PRN120)
5	Elevation	54	Satellite elevation in degrees, (00 ~ 90)
6	Azimuth	069	Satellite azimuth angle in degrees, (000 ~ 359 )
7	SNR	45	C/No in dB (00 ~ 99) Null when not tracking
8	Checksum	72	

## RMC – Recommended Minimum Specific GNSS Data

Time, date, position, course and speed data provided by a GNSS navigation receiver.

Structure:

```
$GPRMC,hhmmss.sss,A,dddmm.mmmm,a,dddmm.mmmm,a,x.x,x.x,ddmmy,,,a*hh<CR><LF>
```

1 2 3 4 5 6 7 8 9 10 11

Example:

```
$GPRMC,111636.932,A,2447.0949,N,12100.5223,E,000.0,000.0,030407,,,A*61<CR><LF>
```

Field	Name	Example	Description
1	UTC time	0111636.932	UTC time in hhmmss.sss format (000000.00 ~ 235959.999)
2	Status	A	Status 'V' = Navigation receiver warning 'A' = Data Valid
3	Latitude	2447.0949	Latitude in dddmm.mmmm format Leading zeros transmitted
4	N/S indicator	N	Latitude hemisphere indicator 'N' = North 'S' = South
5	Longitude	12100.5223	Longitude in dddmm.mmmm format Leading zeros transmitted
6	E/W Indicator	E	Longitude hemisphere indicator 'E' = East 'W' = West
7	Speed over ground	000.0	Speed over ground in knots (000.0 ~ 999.9)
8	Course over ground	000.0	Course over ground in degrees (000.0 ~ 359.9)
9	UTC Date	030407	UTC date of position fix, ddmmyy format
10	Mode indicator	A	Mode indicator 'N' = Data not valid 'A' = Autonomous mode 'D' = Differential mode 'E' = Estimated (dead reckoning) mode 'M' = Manual input mode 'S' = Simulator mode
11	checksum	61	

**VTG – Course Over Ground and Ground Speed**

The Actual course and speed relative to the ground.

Structure:

```
GPVTG,x.x,T,,M,x.x,N,x.x,K,a*hh<CR><LF>
    1    2    3    4 5
```

Example:

```
$GPVTG, 000.0,T,,M,000.0,N,0000.0,K,A*3D<CR><LF>
```

Field	Name	Example	Description
1	Course	000.0	True course over ground in degrees (000.0 ~ 359.9)
2	Speed	000.0	Speed over ground in knots (000.0 ~ 999.9)
3	Speed	0000.0	Speed over ground in kilometers per hour (0000.0 ~ 1800.0)
4	Mode	A	Mode indicator 'N' = not valid 'A' = Autonomous mode 'D' = Differential mode 'E' = Estimated (dead reckoning) mode 'M' = Manual input mode 'S' = Simulator mode
5	Checksum	3D	

## ORDERING INFORMATION

Part Number	Description
Venus634LPx-T	Single Chip Timing Mode GPS Receiver Module

SkyTraq Technology, Inc.  
4F, No.26, Minsiang Street, Hsinchu, Taiwan, 300  
Phone: +886 3 5678650  
Fax: +886 3 5678680  
Email: info@skytraq.com.tw

© 2008 SkyTraq Technology Inc. All rights reserved.

Not to be reproduced in whole or part for any purpose without written permission of SkyTraq Technology Inc ("SkyTraq"). Information provided by SkyTraq is believed to be accurate and reliable. These materials are provided by SkyTraq as a service to its customers and may be used for informational purposes only. SkyTraq assumes no responsibility for errors or omissions in these materials, nor for its use. SkyTraq reserves the right to change specification at any time without notice.

These materials are provided "as is" without warranty of any kind, either expressed or implied, relating to sale and/or use of SkyTraq products including liability or warranties relating to fitness for a particular purpose, consequential or incidental damages, merchantability, or infringement of any patent, copyright or other intellectual property right. SkyTraq further does not warrant the accuracy or completeness of the information, text, graphics or other items contained within these materials. SkyTraq shall not be liable for any special, indirect, incidental, or consequential damages, including without limitation, lost revenues or lost profits, which may result from the use of these materials.

SkyTraq products are not intended for use in medical, life-support devices, or applications involving potential risk of death, personal injury, or severe property damage in case of failure of the product.

## Change Log

Version 0.2, August 3, 2009

1. Added operation section

Version 0.1, July 29, 2009

1. Initial release